



8LV-320Z / 8LV-370Z Series

Configuration	4-stroke, vertical, water cooled diesel engine
Maximum output at crankshaft according ISO 8665:2006	235 kW @ 3.800 rpm / 272 kW @ 3.800 rpm (320 mhp @ 3.800 rpm) / (370 mhp @ 3.800 rpm)
Continuous rating output at crankshaft	214 kW @ 3,683 rpm / 248 kW @ 3.683 rpm
Displacement	4,46 Ltr (272,24 cu in)
Bore x stroke	86 mm x 96 mm (3.38 in x 3.78 in)
Cylinders	8 in V-90°
Combustion system	Direct injection Common-rail system
Compression Ratio	15:8
Low Idle rpm	550 rpm
Aspiration	Turbocharged with twin TC
Electric system	12V
Alternator	12V - 180A
Start-assist	Glow-plug system
Cooling system	Fresh water cooling by centrifugal fresh water pump Sea water cooling by rubber impeller seawater pump
Lubrication system	Enclosed, forced lubricating system
Direction of rotation (crankshaft)	Counter clockwise viewed from flywheel side
Dry weight without sterndrive	435 Kg (959 Lbs)
Environmental	EU RCD, *EPA TIER 3, EMC
Engine mounting	Rubber type flexible mounting

NOTE: Fuel condition: Density at 15°C = 0.84 g/cm³ Fuel temperature 40°C at the inlet of the fuel injection pump (ISO 8665:2006)

Dimensions (For detailed line-drawings, please refer to our web-site: www.yanmarmarine.com or contact your supplier)

* Engine is capable of meeting EPA Tier 3 emission regulations

Gear view

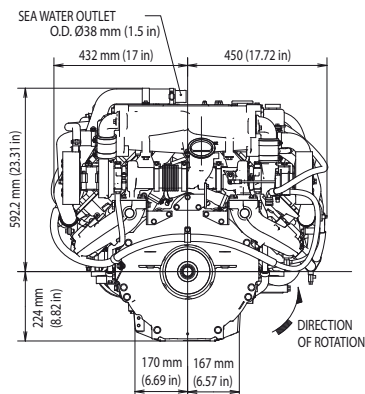

Right side view

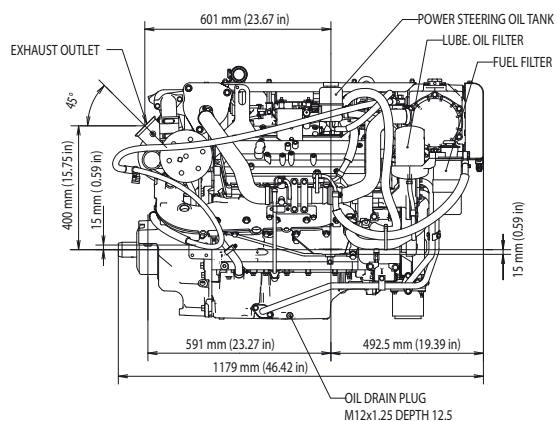

Performance Curves (Output is according ISO 8665)

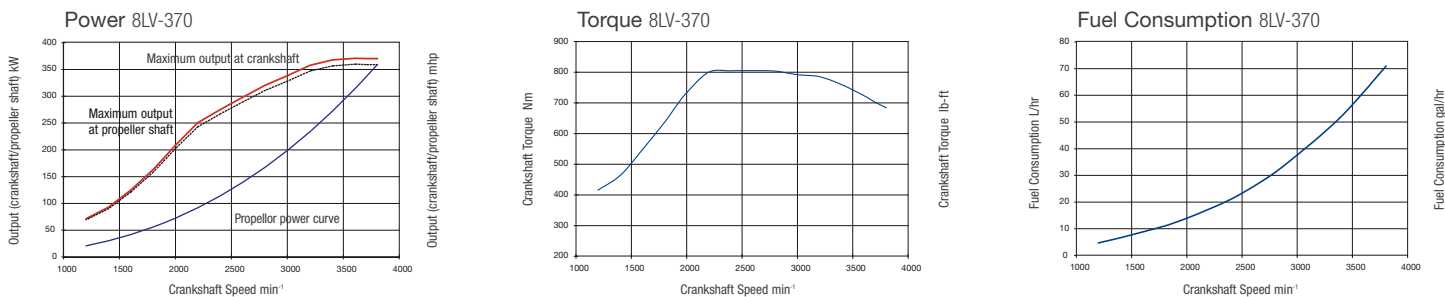

Drive systems

Model	ZT370 (Steerable Z-drive with dual prop)	
Type	Hydraulic Actuated Multi-friction disc clutch	
Dry Weight with propellers	112 KG (247 lbs)	
Reduction Ratio	1,65/1,65	1,78/1,78
propellor speed	2424/2424	2247/2247
Direction of rotation viewed from the stern	Clockwise (rear prop) & Counterclockwise (front prop)	
Lub oil specifications	API class: GL5 SAE grade #80W90	
Dry weight engine with sterndrive	547 kg (1205 lbs)	
Shift control	Mechanical or Electro-magnetic	
Trim range	-6° - +10°	
Trailer limit	51°	

Control system

- Yanmar CAN-bus control system
- Electronic CAN-bus Control-head
- Multi-function colour display
- NMEA2000 or J1939 gauge output
- Second or third station - optional