

# Yanmar type 4BY2-150Z

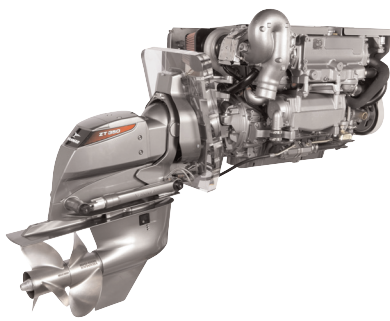

<b>Configuration</b>	In line, 4-stroke cycle, water cooled diesel engine
<b>Maximum output at crankshaft *</b>	110 kW (150 mhp) / 4000 rpm
<b>Continuous rating output at crankshaft</b>	85 kW (114 mhp) / 3600 rpm
<b>Displacement</b>	1.995 L (122 cu in)
<b>Bore x stroke</b>	84 mm x 90 mm (3.31 in x 3.54 in)
<b>Cylinders</b>	4, Common Rail with vertical injectors
<b>Combustion system</b>	Direct injection
<b>Aspiration</b>	Wastegated, turbocharged with intercooler
<b>Starting system</b>	Electric starting 12 V - 2 kW
<b>Alternator</b>	12 V - 150 A
<b>Cooling system</b>	Fresh water cooling with heat exchanger, and sea water cooled charge air cooler
<b>Lubrication system</b>	Totally enclosed, forced lubricating system with pump
<b>Can Bus</b>	According to NMEA 2000 protocol
<b>Direction of rotation (crankshaft)</b>	Counter clockwise viewed from flywheel side
<b>Dry weight without sterndrive</b>	258 kg (569 lbs)
<b>Environmental</b>	EU RCD, US EPA Tier2, BSO II & EMC
<b>Engine mounting</b>	Rubber type antivibration mounts

NOTE: Fuel condition: Density at 15°C = 0.84 g/cm<sup>3</sup>; 1kW = 1.3596 mhp = 1.3410 HP  
 \* Fuel temperature 40°C at the inlet of the fuel injection pump (ISO 8665 : 2006)

**Dimensions** (For detailed line-drawings, please refer to our web-site: [www.yanmarmarine.com](http://www.yanmarmarine.com) or contact your supplier)

## Front view

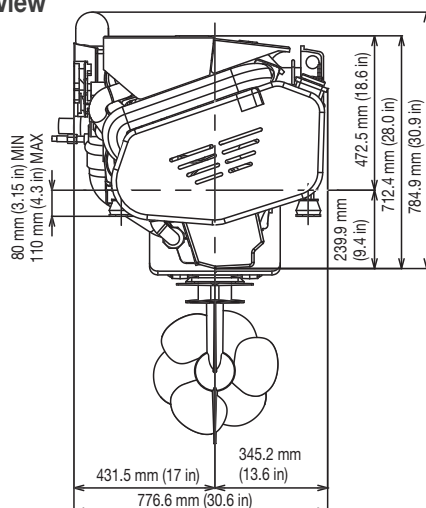

## Right side view

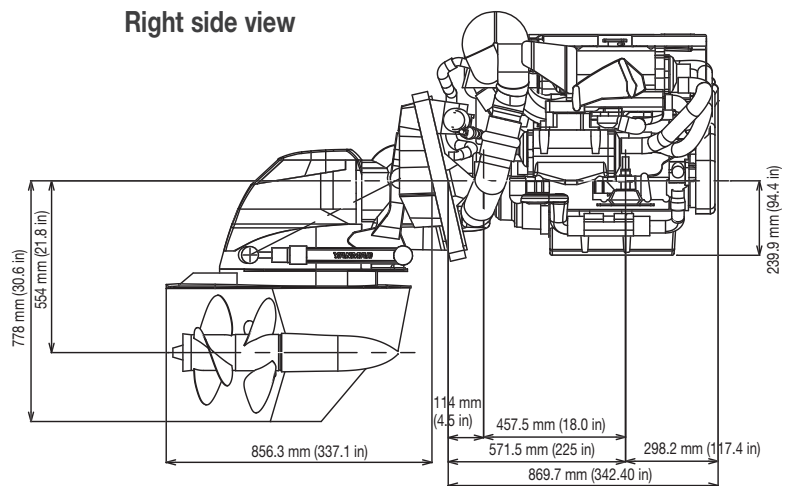

4BY2-150Z with Yanmar Sterndrive ZT350

## Performance Curves (Output is according ISO 8665 )

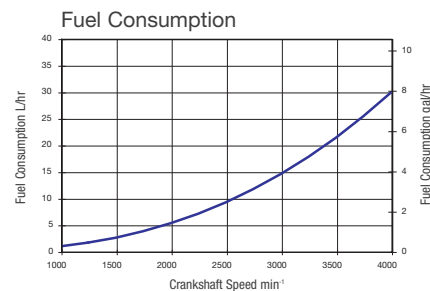
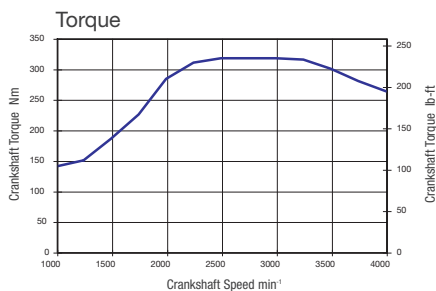
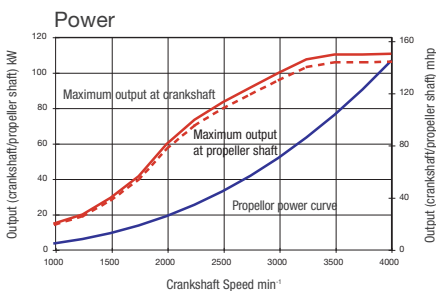

## Yanmar sterndrive set Engine

Model	Yanmar Sterndrive ZT350			
Type	ZT350			
Dry weight with propellers	112 kg (247 lbs)			
Reduction ratio (fwd/asn)	1.65/1.65	1.78/1.78	1.97/1.97	2.18/2.18
Propeller speed (fwd/asn)	2424/2424	2247/2247	2030/2030	1835/1835
Direction of rotation (propeller shaft - fwd)	Clockwise & counter clockwise viewed from flywheel side			
Dry weight engine with sterndrive	370 kg (816 lbs)			

- 1, Inner and outer transom surface must be parallel within 3mm in area covered by transom plates and remain within transom thickness limits.
- 2, Area covered by gimbal housing assembly must be flat to within 1.6mm.
- 3, Area covered by inner transom plate must be flat to within 3.2mm
- 4, Transom angle: 13° to 16°
- 5, Also available with: BravoX-1 and BravoX-2. Contact your local supplier for available configurations

## Instrument Panels

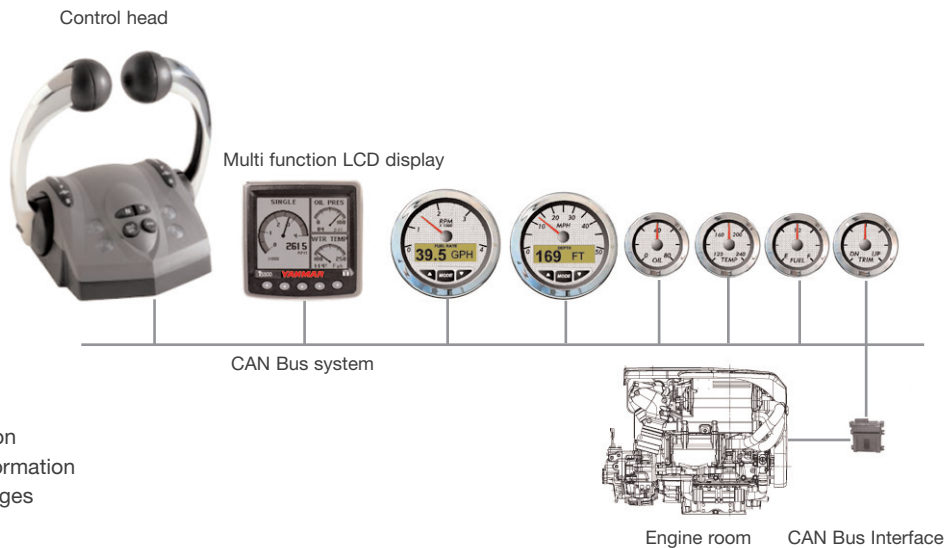

- Multi function LCD display:
- engine information
  - maintenance information
  - diagnosis messages

## Engine Accessories

### Standard Engine Package System

- Alternator 12V - 150A single pole
- Protection cover for engine transmission
- High riser mixing elbow
- Flexible Mounts
- Glow plug controller and related parts

### Optional Engine Package System

- Exhaust side dipstick
- Electrical Gearshift

## Electronic Control System

### Standard Electronic Control

- Electronic Control Head
- LCD display

### Optional Electronic Control

- Various engine Monitoring gauges
- Various engine Control heads