

3JH5E Series

Configuration	4-stroke, vertical, water cooled diesel engine
Maximum output at crankshaft	28.7 kW (38,5 mhp) / 3000 rpm
Continuous rating output at crankshaft	26,1 kW (35 mhp) / 2907 rpm
Displacement	1,642 L (100 cu in)
Bore x stroke	88 mm x 90 mm (3.46 in x 3.54 in)
Cylinders	3 in line
Combustion system	Direct injection
Aspiration	Natural aspiration
Starting system	Electric starting 12 V - 1.4 kW
Alternator	12 V - 80 A
Cooling system	Fresh water cooling by centrifugal fresh water pump and rubber impeller sea water pump
Lubrication system	Enclosed, forced lubricating system
Direction of rotation (crankshaft)	Counter clockwise viewed from flywheel side
Dry weight without gear	173 kg (381 lbs)
Environmental	EU RCD, EPA TIER 3, EMC
Engine mounting	Rubber type flexible mounting

NOTE: Fuel condition: Density at 15°C = 0.84 g/cm³
Fuel temperature 40°C at the inlet of the fuel injection pump (ISO 8665 : 2006)

Dimensions (For detailed line-drawings, please refer to our web-site: www.yanmarmarine.com)

Front view

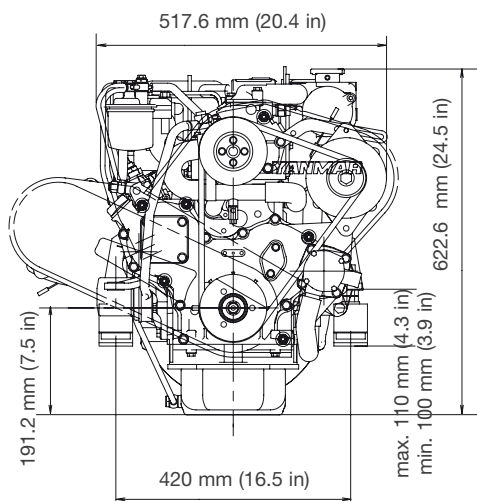

Right side view

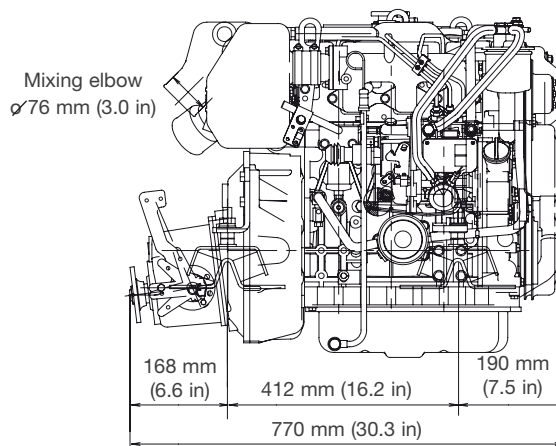

Performance Curves (Output is according ISO 8665)

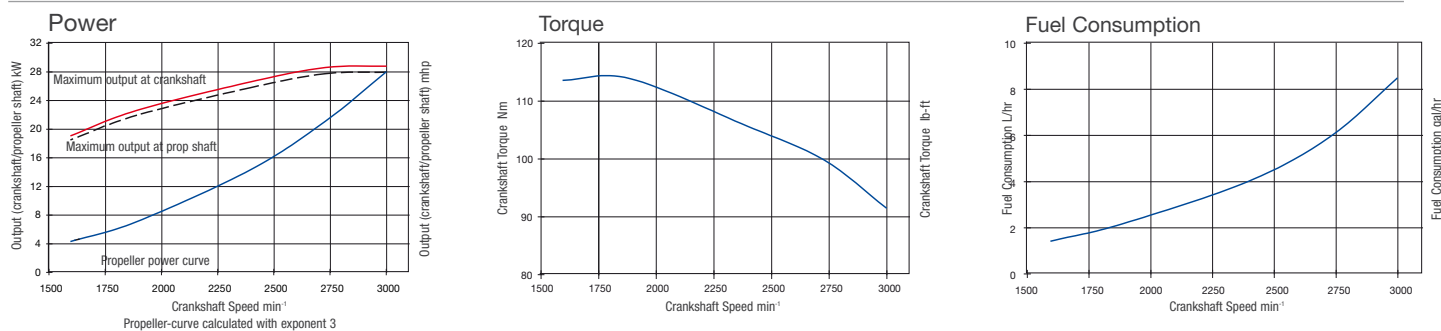

Marine Gears/Drive

Model	KM35P		KM35A (down angle: 7deg)		Saildrive (SD50)
Type	Mechanical cone clutch		Mechanical cone clutch		Mechanical cone clutch
Dry weight	12 kg (27 lbs)		13 kg (29 lbs)		40 kg (88 lbs)
Reduction ratio (fwd/asn)	2.36/3.16	2.61/3.16	2.33/3.04	2.64/3.04	2.32/2.32
Propeller speed(fwd/asn)	1271/949	1149/949	1288/987	1136/987	1293/1293
Direction of rotation	Clockwise viewed from the stern				Clockwise & counter clockwise viewed from flywheel side
Dry weight engine and gear/drive	185 kg (408 lbs)		186 kg (410 lbs)		213 kg (470 lbs)
Length engine and gear/drive	777 mm (31 in)		776 mm (31 in)		973 mm (38 in)

Instrument Panels



Digital B-panel and C-panel with keyswitch	Digital B-panel and C-panel keyless
Keyswitch	Sealed rocker switch for engine on/start
Stop Button	Sealed rocker switch for glow function
Tachometer with hour	Tachometer with hour
Indication (display)	Indication (display)
Audible alarm	Audible alarm
Alarm lights	Alarm lights
Battery low charge	Battery low charge
Coolant High temperature	Coolant High temperature
Lubricating oil low pressure	Lubricating oil low pressure
Water in saildrive seal	Water in saildrive seal
Extra for all C-panels: Coolant temperature gauge, Lubricating oil pressure gauge	

Accessories

Standard Features

- Set of flexible engine mounts
- Exhaust mixing elbow (L-type)
- V-belt safety cover
- Fresh water expansion tank
- Alternator 12 V - 80 A
- Electric stop solenoid
- Operation manual

Optional

- Digital B panel keyless
- Digital C panel with key switch or key less
- Second Alternator 12V80A, 12V130A or 24V75A
- High riser mixing (Instead of L-Elbow)
- 4M, 6M, 10M Extension Wire harness
- Hot water kit with cocks
- Second station harness