

Quick Specs

Max. Output at Crankshaft	220/260 mhp / 4,000 rpm
Total Displacement	1.995 L
Configuration	4-stroke cycle
Cylinders	4
Engine Weight	694 lbs

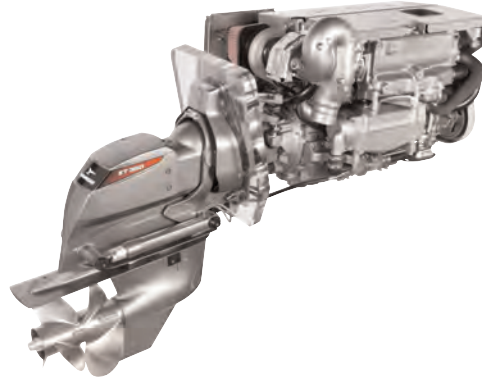

6BY3-220Z/260Z

4 Valves Per Cylinder makes for better fuel/air mixture, delivering more power and lower emissions.

Cast Aluminum Oil Pan increases durability and provides for improved heat dissipation.

Belt Safety Guard provides complete protection from belts and moving components.

Fully Electronic Control increases efficiency and lowers emissions.

High quality two part urethane paint protects surfaces from rust.

Compact. Light Weight. Smooth and Quiet.

Yanmar engines are designed for high performance and maximum engine life.

Tested under the most extreme conditions, you can always count on Yanmar engines to deliver the power you need day in and day out, year after year. It's simply the best power package available for new vessels and re-power applications.

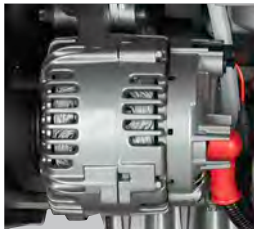

150A Alternator

Provides maximum power for the cruiser and all electronic needs.



CAN Bus Output In NMEA 2000® Protocol

The engine data can be read and displayed by a wide variety of electronic equipment.



Convenient Service Points

Makes it easy to perform routine maintenance or handle unexpected repairs.



6BY3-220Z/260Z

specifications

Configuration	In line, 4-stroke, 6 cylinder, common rail fuel injection
Maximum output at crankshaft	220/260 mhp (162/191 kW) @ 4000 rpm
Continuous rating output at crankshaft	201/237 mhp (148/174 kW) @ 3876 rpm
Displacement	2.993 L (183 cu in)
Bore x stroke	3.31 in x 3.54 in (84 mm x 90 mm)
Aspiration	Wastegated, turbocharged with intercooler
Alternator	12 V - 150 A
Cooling system	Fresh water cooling with heat exchanger, and sea water cooled charge air cooler
Electronic Control	NMEA 2000® certified
Direction of rotation (crankshaft)	Counter clockwise viewed from flywheel side
Dry weight without sterndrive	694 lbs (315 kg)
Environmental Certification	Meets comprehensive emissions regulations in EU RCD, US EPA BSO II & EMC
Engine mounting	Flexible type isolators

NOTE: Fuel condition: Density at 15°C = 0.84 g/cm³; 1kW = 1.3596 mhp = 1.3410 HP
 * Fuel temperature 40°C at the inlet of the fuel injection pump (ISO 8665)
 Technical data is according to ISO 8665 / 3046

YANMAR STERNDRIVE

Type	Yanmar ZT350			
Dry weight with propellers	247 lbs (112 kg)			
Reduction ratio (fwd/asn)	1.65/1.65	1.78/1.78	1.97/1.97	2.18/2.18
Propeller speed (fwd/asn)	2424/2424	2247/2247	2030/2030	1835/1835
Direction of rotation (propeller shaft - fwd)	Clockwise & counter clockwise viewed from flywheel side			
Dry weight engine with sterndrive	941 lbs (427 kg)			
Length engine without sterndrive	39 in (1001 mm)			

NMEA2000® Control System

Multi function LCD display:

- engine information
- maintenance information
- diagnosis messages

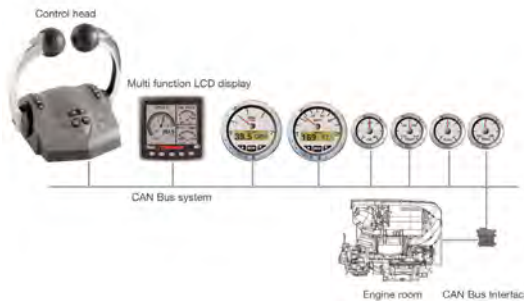

Rear View

Right Side View

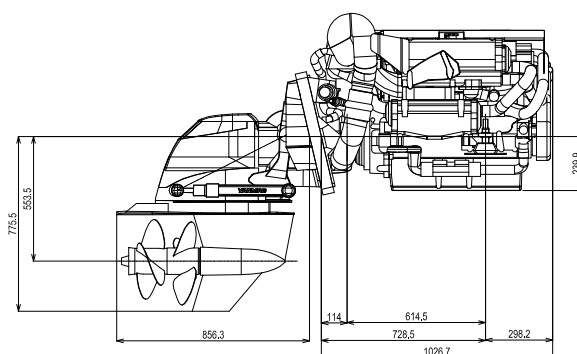
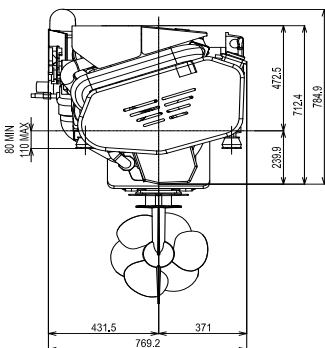

PERFORMANCE CURVES

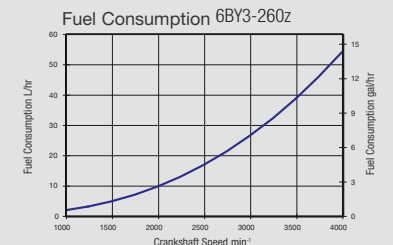
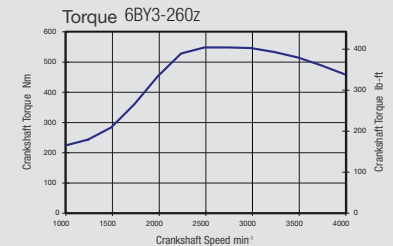
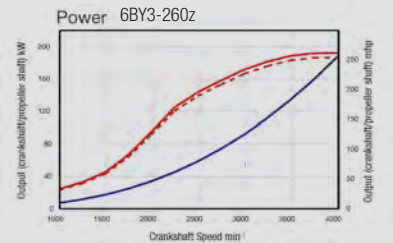
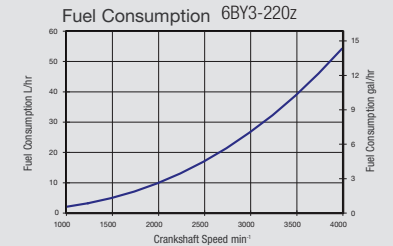
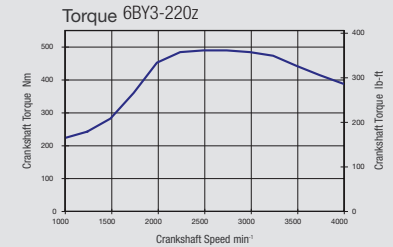
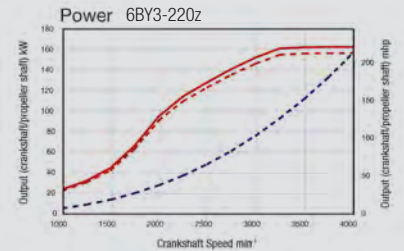

WWW.US.YANMAR.COM