

# Yanmar type 4JH4-HTE

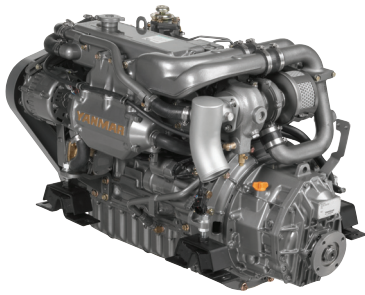

<b>Configuration</b>	4-stroke, vertical, water cooled diesel engine
<b>Maximum output at crankshaft</b>	* 80.9 kW ( 110 mhp) / 3200 rpm
<b>Continuous rating output at crankshaft</b>	73.6 kW (99 mhp) / 3100 rpm
<b>Displacement</b>	1.995 L ( 121.7 cu in)
<b>Bore x stroke</b>	84 mm x 90 mm ( 3.31 in x 3.54 in)
<b>Cylinders</b>	4 cylinders, 4-valves per cylinder
<b>Combustion system</b>	Direct injection
<b>Aspiration</b>	Turbocharged
<b>Starting system</b>	Electric starting 12 V - 1.4 kW
<b>Alternator</b>	12 V - 80 A
<b>Cooling system</b>	Fresh water cooling by centrifugal water pump and rubber impeller sea water pump
<b>Lubrication system</b>	Enclosed, forced lubricating system
<b>Direction of rotation (crankshaft)</b>	Counter clockwise viewed from flywheel side
<b>Dry weight without gear</b>	217 kg (478 lbs)
<b>Environmental</b>	EU RCD, US EPA Tier2, BSO II & EMC
<b>Engine mounting</b>	Rubber type flexible mounts

NOTE: Fuel condition: Density at 15°C = 0.84 g/cm<sup>3</sup>; 1kW = 1.3596 mhp = 1.3410 HP  
 \* Fuel temperature 40°C at the inlet of the fuel injection pump (ISO 8665)  
 Technical data is according to ISO 8665 / 3046

**Dimensions** (For detailed line-drawings, please refer to our web-site: [www.yanmarmarine.com](http://www.yanmarmarine.com) or contact your supplier)

**Rear view**

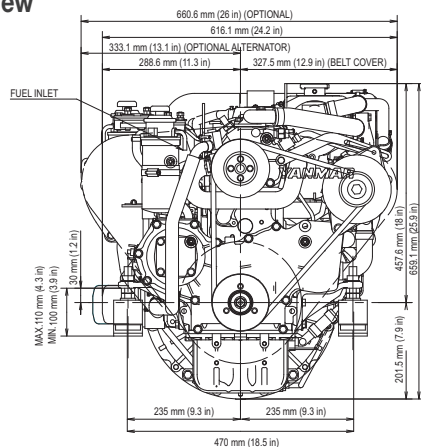

**Right side view**

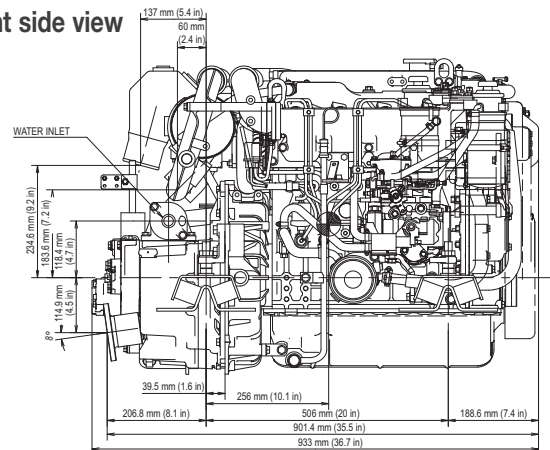

4JH4-HTE with KMH4A marine gear

## Performance Curves (Output is according ISO 8665)

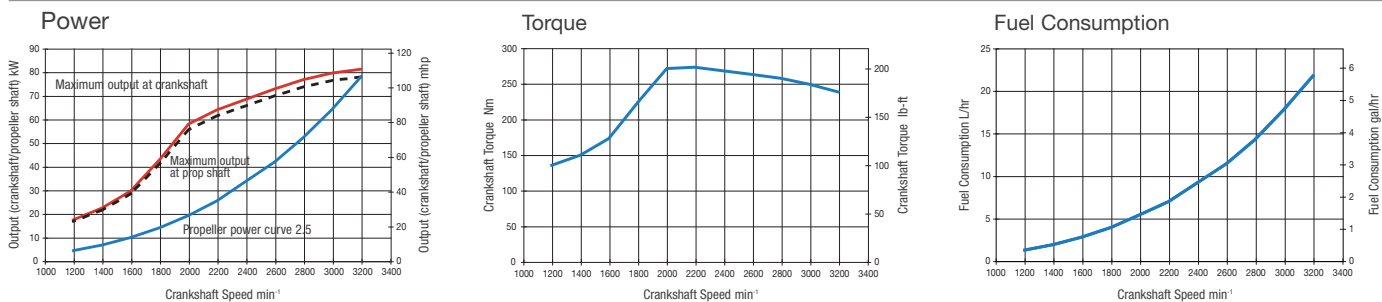

## Marine Gears/Drive

Model	ZF30M parallel	KM4A2 down angle:7°	KMH4A down angle: 8°	ZF25A down angle: 8°
Type	Mechanical multi disc	Mechanical wet cone clutch	Hydraulic, wet multi-disc	Hydraulic, wet multi-disc
Dry weight	28 kg (61 lbs)	30 kg (66 lbs)	31 k (68 lbs)	30 kg (66 lbs)
Reduction ratio (fwd/asn)	2.15/2.64 2.70/2.64	1.47/1.47 2.14/2.14 2.63/2.63	2.04/2.04 2.45/2.45	1.93/1.93 2.48/2.48
Propeller speed at cont. rating (fwd/asn)	1488/1212 1185/1212	2177/2177 1495/1495 1217/1217	1569/1569 1306/1306	1658/1658 1290/1290
Direction of rotation (propeller shaft - fwd)	Clockwise viewed from flywheel side	Clockwise or counterclockwise viewed from flywheel side	Clockwise or counterclockwise viewed from flywheel side	Clockwise & counter clockwise viewed from flywheel side
Dry weight engine and gear/drive	245 kg (540 lbs)	247 kg (545 lbs)	248 kg (547 lbs)	247 kg (545 lbs)
Length engine and gear/drive	923 mm (36.3 in)	903 mm (35.6 in)	933 mm (36.7 in)	1017 mm (40 in)

## Instrument Panels

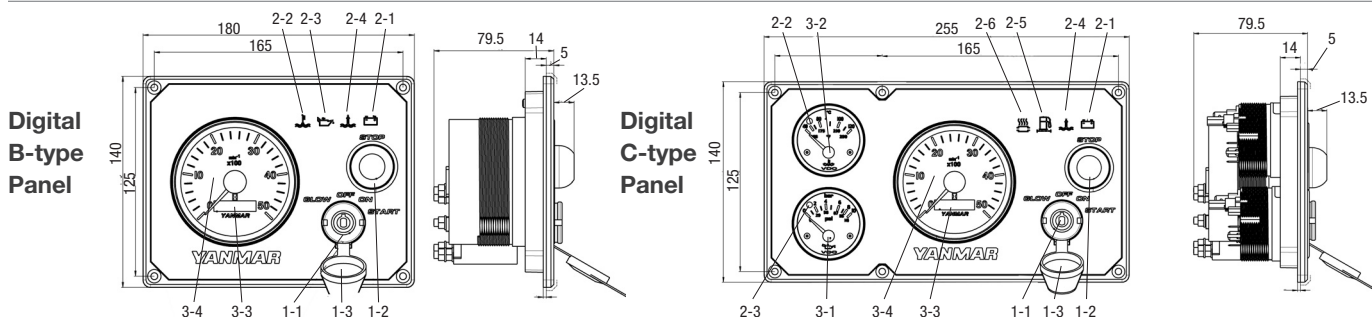

Function	Type of instrument panel	
	Digital B-type Panel	Digital C-type Panel
<b>① Switch unit</b>		
1-1 Key switch for GLOW/OFF/ON/START (4-position switch)	O	O
1-2 Push button switch for engine stop	O	O
1-3 Moisture cap for key switch	O	O
<b>② Alarm lamp unit</b>		
2-1 Battery low charge alarm	O	O
2-2 Coolant high temperature alarm	O	O
2-3 Lubricating oil low pressure	O	O
2-4 Water in sail drive seal alarm	O	O
2-5 Water in fuel filter alarm (optional)	X	O
<b>③ Meters</b>		
3-1 Lubricating oil pressure meter	X	O
3-2 Coolant temperature meter	X	O
3-3 Hour meter	O	O
3-4 Tachometer	O	O
<b>④ Audible alarm buzzer</b>	O	O

Note: O = Equipped on panel X = Not equipped on panel

## Accessories

### Standard Package

- Set of flexible mounts
- Exhaust mixing elbow (L-type)
- V-belt safety cover
- Expansion tank for fresh water cooling system
- Alternator 12 V - 80 A
- Electric stop solenoid

### Optional

- Digital B or C type instrument panel
- Second Alternator 12V130A or 24V75A
- Exhaust mixing elbow (U-type)
- Various extension wire harnesses (4M, 6M, 10M)
- Hotwaterkit with or without cocks

Texts and illustrations are not binding. Yanmar Marine reserves the right to introduce adaptations without prior notification.

4JH4-HTE Version: 2008-06