

Crusader Captain's Choice

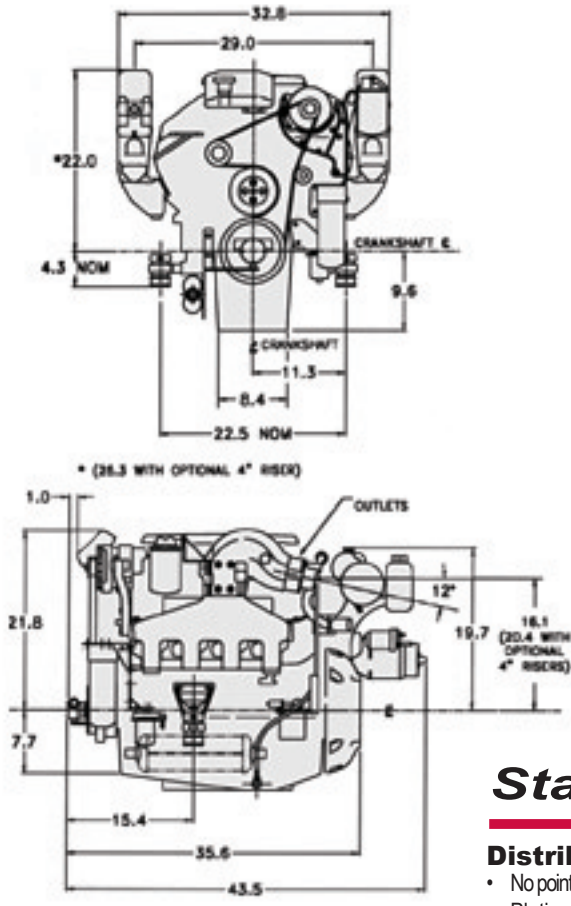

Specifications

Captain's Choice

Displacement
Cylinders
Bore & Stroke
Compression
Main Bearings
Rated Power*
Fuel System
Full Throttle RPM
Rotation
Exhaust Outlet
Valve Lifters
Length
Width
Overall Height
Total Weight w.1:1

8.1 MPI

8.1L/496 c.i.d.
V-8
4.25"X4.37"
9.1:1
4-bolt cast iron
385 hp @ 4400 rpm
Multiport Fuel Injection
4200-4400 rpm
LH
4"OD
Hydraulic
43.5"
32.8"
31.4"
1200 lbs

8.1 HO

8.1L/496 c.i.d.
V-8
4.25"X4.37"
9.1:1
4-bolt cast iron
425 hp @ 5000 rpm
Multiport Fuel Injection
5000
LH
4"OD
Hydraulic
43.5"
32.8"
31.4"
1200 lbs

Standard Features

Cooling System

- Full freshwater cooling
- Rear-mounted heat exchanger with easy maintenance reservoir
- Dependable dual engine/transmission cooler
- High-mounted, high volume stainless steel raw water pump
- Thermostatically controlled cooling system

Exhaust System

- Pyramidal exhaust manifold
- High level exhaust discharge
- Free breathing ported manifolds
- Reversible exhaust riser system

Electrical System

- Electronic Ignition
- 12-volt negative ground system
- High output 65-amp alternator (100 amp optional)
- Overload damage protection by a manual reset circuit breaker
- Pre-wired wiring harness with 10-prong disconnect
- High-torque positive-engagement top-mount marine starter
- Temperature, oil pressure and voltage sending unit
- Electrical component moisture cover
- Marine approved automatic mechanical advance distributor

Distributorless Ignition

- No points, rotor, condenser, or cap
- Platinum-tipped spark plugs for long life
- Longer maintenance intervals

Electronic Fuel Injection

- Instant starting
- Precise throttle response
- Outstanding cruising and top-end performance
- Increased fuel efficiency

Engine Management System

- Knock sensor adjusts for low octane fuel
- Automatic spark advance provides peak performance in all operating conditions
- Monitors the vital signs of the lubrication and cooling systems
- Rev limiter prevents engine damage from overrevving

Exclusive Fuel Control Cell™

- Eliminates need for specially modified fuel tank or EFI installations
- Eliminates vapor lock
- Protects EFI system against contaminated fuel
- Premium, extra large fuel filter/water separator
- Easy to reach and service

Smooth-Ride™ Mounting System

- Precision precompressed adjustable mount
- Vibration isolators for vibration-free performance
- Versatile six-way adjustment for ease of installation
- Unique rear mount system provides lateral support for added stability and strength
- Self-adjusting to stringer surface

Lubrication System

- Full pressure full flow filtering system
- Positive crankcase ventilation

Transmissions Options

- Compatible with all major transmissions

Miscellaneous

- Membership in the Crusader Captain's Club
- Owner's manual
- Single serpentine belt
- Multi-coat non-corrosive paint protection
- U.S. Coast Guard approved flame arrester

Warranty

- 3-Year Buyer Protection Plan

Crusader®

On Open Water, It's Priceless

40580 Van Dyke Rd, Suite E
Sterling Heights, MI 48313
crusaderengines.com

Local Dealer