

MARINE DIESEL ENGINES

PLEASURE-CRAFT POWER

YANMAR

INSTRUMENT PANELS

			New C-type	New D-type
①	Switch	Key switch (Starter switch)	●	●
		Engine stop switch	●	●
		Alarm buzzer (C.W. temp., L.O. pressure)	●	●
		Alarm buzzer stop switch	●	●
		Illumination switch for meters	●	●
②	Alarm lamp unit	Battery not charging	●	●
		C.W. high temperature	●	●
		L.O. low pressure	●	●
		Boost pressure high (for 4LHA-STE)	●	●
③	Tachometer	Tachometer with hour meter	●	●
		L.O. pressure meter	●	●
④	Sub meter unit	C.W. temperature meter	●	●
		Boost meter (Turbo)	—	●
		Quartz clock	—	●

A Powerful New Force in Motorboating

- This is Yanmar's motor boat diesel engine that gives a total of 465 x 2 or 930hp (684kW) in a twin installation. It is aimed at the high volume twin diesel propulsion market from around 32 to 42 feet.

- Featuring Yanmar's latest lightweight engine construction technology in a compact package, this power plant exhibits superb fuel efficiency and a power-to-weight ratio that makes possible a higher top speed and a longer cruising range using the same fuel tank.

- The increased horsepower in this straight 6 cylinder engine is obtained from a longer stroke, also from more aggressive turbo/intercooler and tune settings. It also features 4 valves per cylinder and an extra high pressure fuel injection system.

- Dimensions of 905mm (35.63in) high and 824mm (32.44in) wide, and with only 825kg of engine weight make for a power installation that is lightweight indeed (1815lbs.).

- We expect the smooth power, together with the flat torque characteristics and low fuel consumption figures of the 6CX-GTE will make it an outstanding choice for any fast boat.

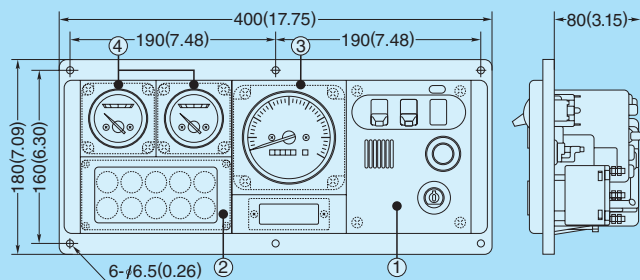

New C-type

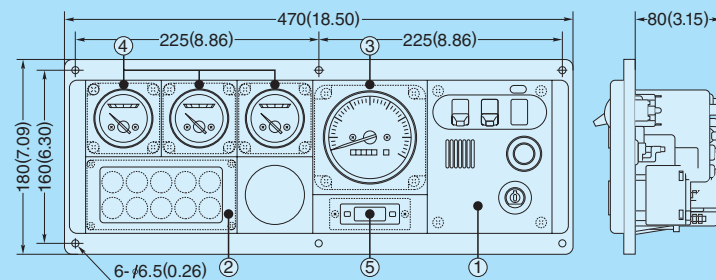

New D-type

Note: All data subject to alteration without notice.

YANMAR DIESEL AMERICA CORP. 901 Corporate Grove Drive, Buffalo Grove, IL 60089

YANMAR EUROPE B.V. Brugplein 11 1332 BS Almere-de Vaart, The Netherlands

YANMAR DIESEL ENGINE CO., LTD. 1-2, 2-chome, Yaesu, Chuo-ku, Tokyo 104, Japan

www.yanmar.com

60A6CX-5/02 4.3M Printed in the USA



IMO Compliant

Photo may show optional equipment

SPECIFICATIONS

Model	6CX-GTE	
Configuration	4-stroke, vertical, water cooled diesel engine	
Number of cylinders	6 in-line	
Bore x Stroke	mm (in.)	100 X 130 (4.33 X 5.12)
Displacement	lit. (cu. in.)	7.413 (452)
Continuous output at flywheel	kW/rpm (hp/rpm)	305/2750 (415/2750)
Maximum output at flywheel	kW/rpm (hp/rpm)	342/2900 (465/2850)
Combustion system	Direct injection	
Aspiration	Turbocharged with intercooler	
Starting System	Electric starting (D.C. 12V, 4.8kW starting motor/12V, 55A alternator)	
Cooling System	Fresh water cooling by centrifugal fresh water pump and rubber impeller seawater pump	
Direction of rotation	Counterclockwise viewed from flywheel	
Dry Weight	kg (lbs)	825 (1815)

Rating condition: ISO 3046/1 [Note]: 1hp= 0.7355kW

DIMENSIONS Unit: mm(in.)

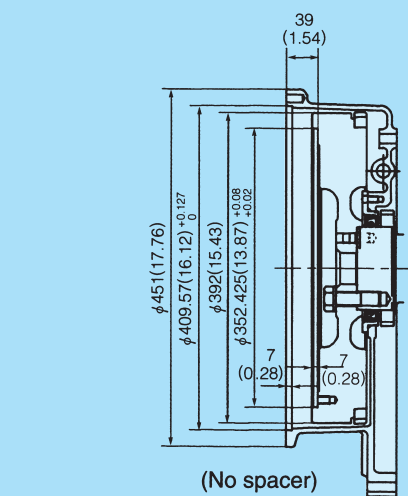
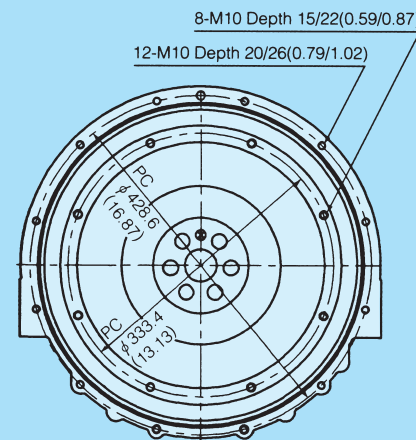

Detail of flywheel

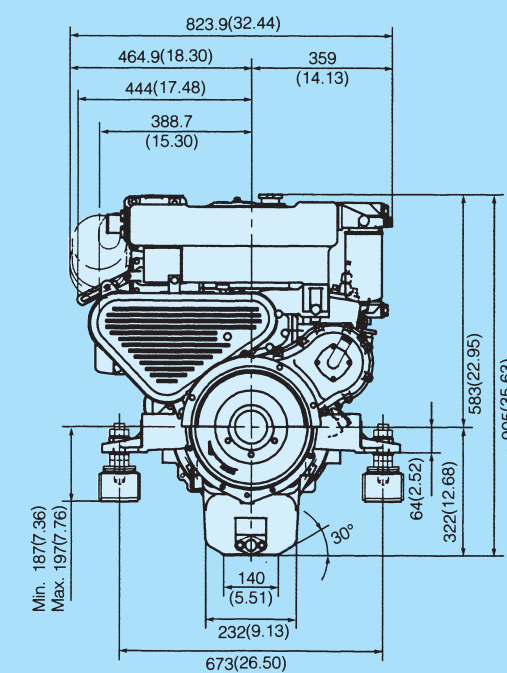
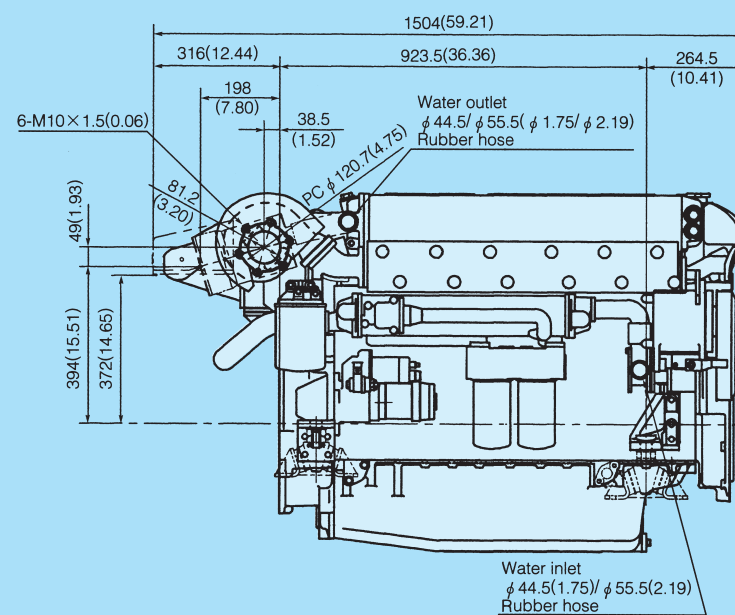
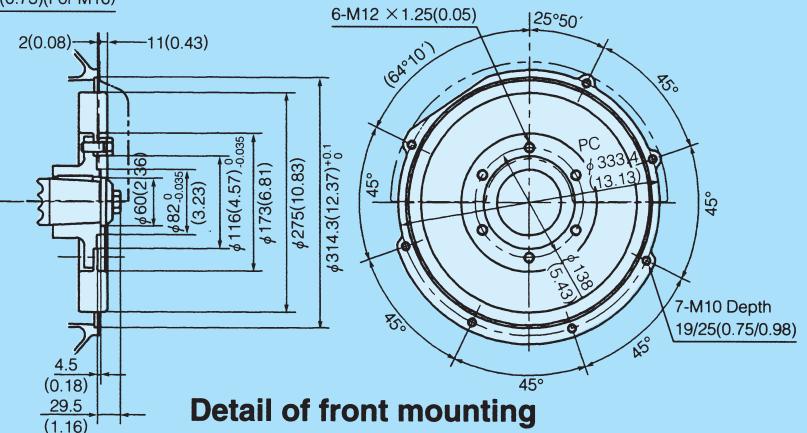
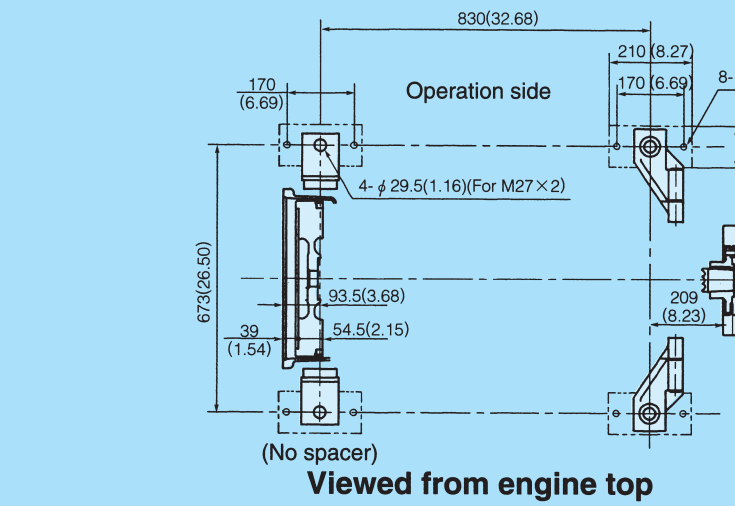
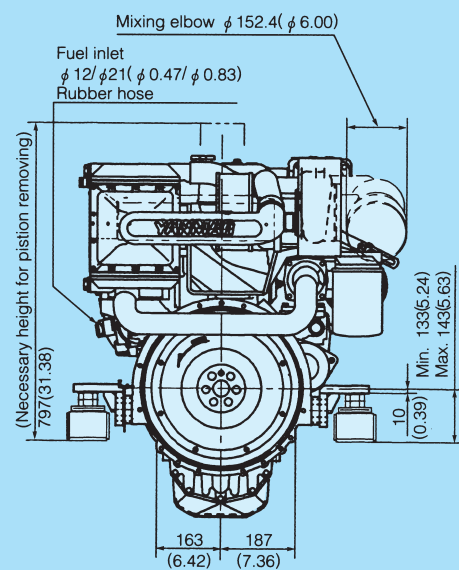

Note:
1. Dwg. shows mounting blocks at compressed height.
[compressed by approx. 3mm(0.12)]
2. Coupling and front mounting are out of scale.

PERFORMANCE CURVES 6CX-GTE

