

SINGLE LEVER TOP MOUNT CONTROLS

Single lever / dual action control to operate both throttle and shift.
Suitable for any type of boats with outboard, inboard or I/O power plants.

FEATURES

- Enables easy and safe shifting by preventing accidental gear engagement unless engine is idling
- Made of marine aluminum, chrome plated or powder coat finish
- Pull-out handle disengages shift for warm-up
- Neutral safety switch X12 - 34543 Q prevents in-gear starting
- Power trim switch conveniently located in the handle grip enables for easy tilting of the engine
- For use with:
 - All Ultraflex control cables except C22 and C4
 - Mercury® \ current OMC® \ Yamaha® \ Suzuki® \ Honda® \ Volvo® style cables
 - 33C style cables
- Ultraflex C5, C16 and Mercury® cables require K35 kit - 34730 U
- Exceeds EN 11547 standard when X12 safety switch is installed

MODELS

- | | |
|---------------|---|
| B65 - 34731 V | Single lever control for one engine, chrome plated |
| B76 - 35312 E | Single lever control for one engine, chrome plated, with trim. |
| B66 - 34732 W | Single lever control for two engines, chrome plated |
| B78 - 35314 G | Single lever control for two engines, chrome plated, with trim. |
| B73 - 35007 T | Single lever control for one engine, black dome, chrome plated lever. |
| B77 - 35313 F | Single lever control for one engine, black dome, chrome plated lever, with trim |
| B74 - 35008 B | Single lever control for two engines, black dome, chrome plated lever. |
| B79 - 35315 H | Single lever control for two engines, black dome, chrome plated lever, with trim. |

B65
B76 with trim



B66
B78 with trim

B73
B77 with trim



B74
B79 with trim

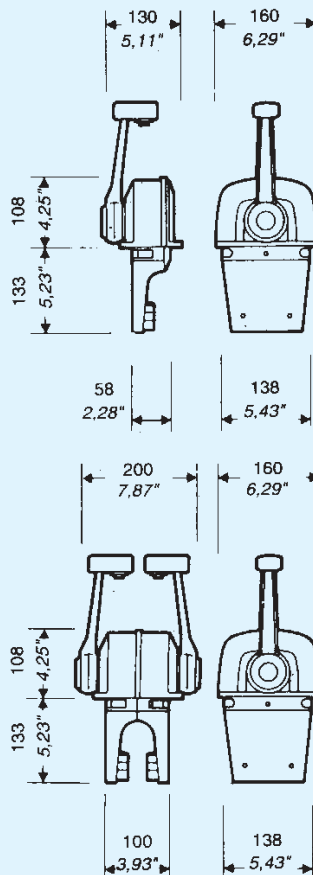

Handle with trim

