

**NON
MAGNETIC
STAINLESS
STEEL
WHEELS**

Non magnetic stainless steel wheels constructed of high grade stainless steel, these wheels have a cast and welded hub and welded spokes at the rim.

- Standard 3/4" taper
- Complete with hub
- Meet with the EN 28848 and ABYC P22 standards

**EXCLUSIVE
POLYURETHANE
"FIRM GRIP"**

V70 - 39442 D
V70W - 39929 J

**STAINLESS STEEL
GRIP**

V42 - 37665 F
V43 - 37666 G
V44 - 37667 H
V47 - 39705 K
V48 - 39706 M

**POLYURETHANE
GRIP**

V43 GFC - 38165 Q Grey
V48 GFC - 39336 E Grey
V43 BFC - 38166 R Black
V48 BFC - 39337 G Black

new



V70 Ø 13.8" (350 mm)

new



V70W Ø 13.8" (350 mm)



V42 - V43 - V44 - V47 - V48



V43GFC - V48GFC



V43BFC - V48BFC

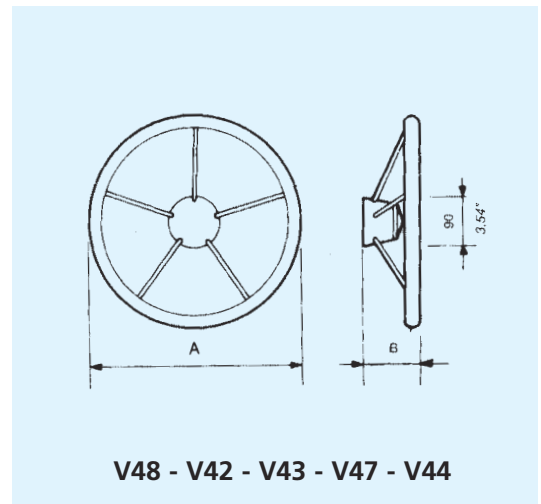

V48 - V42 - V43 - V47 - V44

MODEL	A	B	DISH
V48	13.5" - 343 mm	2.5" - 63,5 mm	25°
V42	15.5" - 394 mm	2.5" - 63,5 mm	10°
V43	15.5" - 394 mm	4.25" - 108 mm	25°
V47	18" - 457 mm	3" - 76 mm	10°
V44	20" - 508 mm	3" - 76 mm	10°

