

# Sea Maxx 8.1 L Series

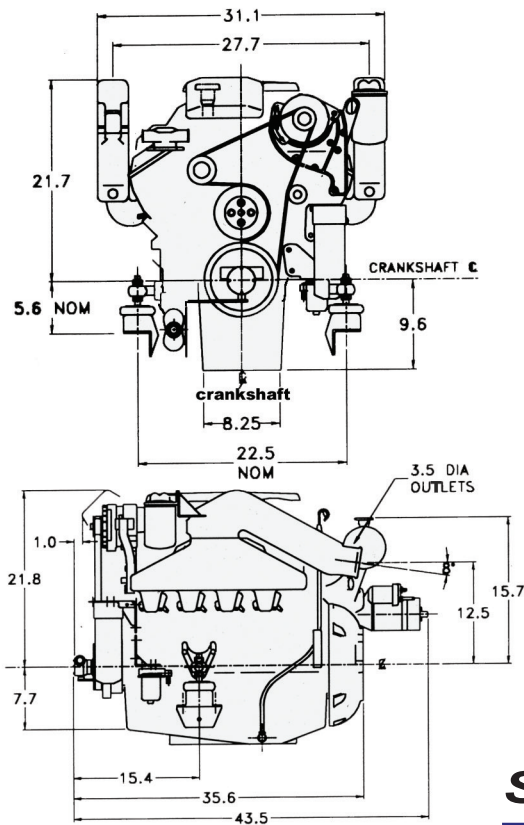

## Specifications

ProFormance Series	8.1 MPI	8.1 HO
Displacement	8.1L/496 c.i.d.	8.1L/496 c.i.d.
Cylinders	V-8	V-8
Bore & Stroke	4.25"X4.37"	4.25"X4.37"
Compression	9.1:1	9.1:1
Main Bearings	4-bolt cast iron	4-bolt cast iron
Rated Power*	385 hp @ 4400 rpm	425 hp @ 5000 rpm
Fuel System	Multiport Fuel Injection	Multiport Fuel Injection
Full Throttle RPM	4200-4400 rpm	5000
Rotation	LH	LH
Exhaust Outlet	4"OD	4"OD
Valve Lifters	Hydraulic	Hydraulic
Length	43.5"	43.5"
Width	31.1"	31.1"
Overall Height	31.4"	31.4"
Total Weight w.1:1	1200 lbs	1200 lbs

## Standard Features

### Cooling System

- Freshwater cooling available
- Rear-mounted heat exchanger with easy maintenance reservoir
- Dependable dual engine/transmission cooler
- High volume stainless steel raw water pump
- Thermostatically controlled cooling system

### Exhaust System

- Pyramidal exhaust manifold
- High level exhaust discharge
- Free breathing ported manifolds
- Reversible exhaust riser system

### Electrical System

- Electronic Ignition
- 12-volt negative ground system
- High output 65-amp alternator (100 amp optional)
- Overload damage protection by a manual reset circuit breaker
- Pre-wired wiring harness with 10-prong disconnect
- High-torque positive-engagement top-mount marine starter
- Temperature, oil pressure and voltage sending unit
- Electrical component moisture cover

### Distributorless Ignition

- No points, rotor, condenser, or cap
- Platinum-tipped spark plugs for long life
- Longer maintenance intervals

### Electronic Fuel Injection

- Instant starting
- Precise throttle response
- Outstanding cruising and top-end performance
- Increased fuel efficiency

### Engine Management System

- Knock sensor adjusts for low octane fuel
- Automatic spark advance provides peak performance in all operating conditions
- Monitors the vital signs of the lubrication and cooling systems
- Rev limiter prevents engine damage from overrevving

### Exclusive Fuel Control Cell™

- Eliminates need for specially modified fuel tank or EFI installations
- Eliminates vapor lock
- Protects EFI system against contaminated fuel
- Premium, extra large fuel filter/water separator
- Easy to reach and service

### Adjust-a-Flex™ Mounting System

- Precision precompressed adjustable mount
- Vibration isolators for vibration-free performance
- Versatile six-way adjustment for ease of installation
- Unique rear mount system provides lateral support for added stability and strength
- Self-adjusting to stringer surface

### Lubrication System

- Full pressure full flow filtering system
- Positive crankcase ventilation

### Transmissions Options

- Compatible with all major transmissions

### Miscellaneous

- Owner's manual
- Single serpentine belt
- Multi-coat non-corrosive paint protection
- U.S. Coast Guard approved flame arrester

### Warranty

- 2-Year Limited Warranty



### Hardcore Offshore Inboards

PO Drawer 369  
Little Mountain, SC 29075  
seamaxx.com

Local Dealer

The policy of Sea MaxxEngines is one of continued improvement. We reserve the right to discontinue options at any time or change specifications, equipment or designs without notice and incurring obligation.